

PACKARD CONTROL---MODEL P-1535

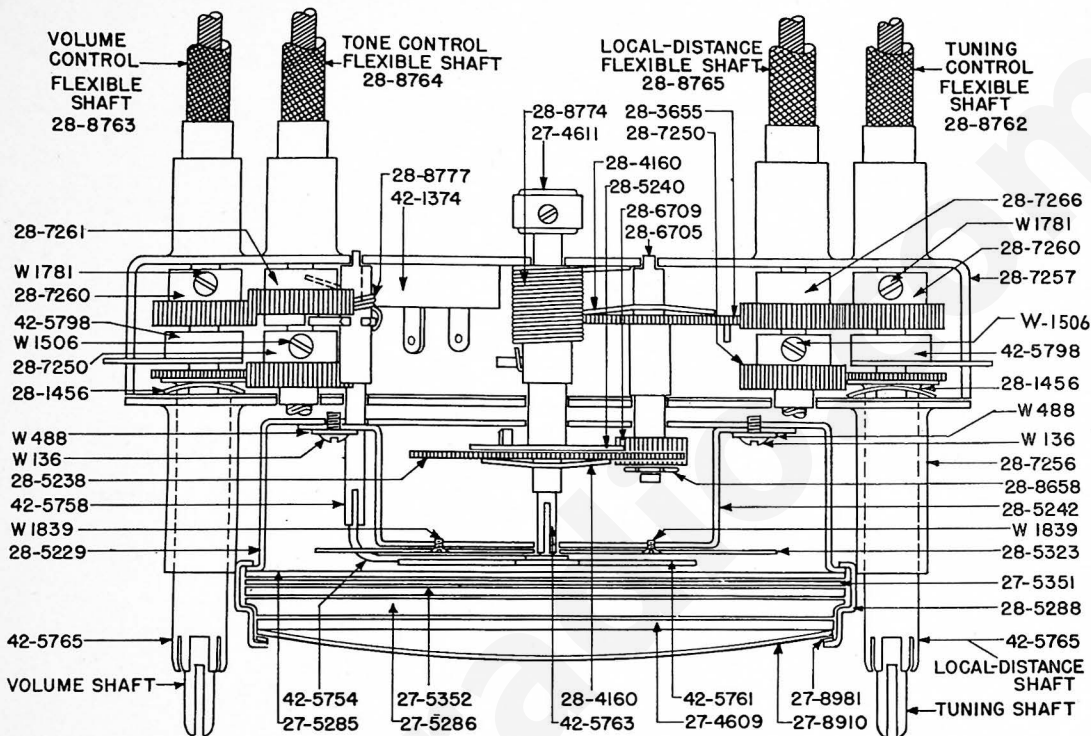

PARTS LIST AND PRICES

(Prices Subject to Change Without Notice)

PART NUMBER	DESCRIPTION	LIST PRICE	PART NUMBER	DESCRIPTION	LIST PRICE
4169	Rubber Washers	per 100 \$1.20	28-5240	Washer	•
W-136	Screw	per 100 .60	28-5242	Bracket	•
W-453	Screw	per 100 1.80	28-5288	Bezel	.40
W-488	Lockwasher	per 100 .35	28-5323	Face	.10
W-775	Button	per 100 1.50	28-6705	Intermediate Gear	•
W-814	Screw	per 100 .75	28-6709	Dial Gear (small)	•
W-874	Lockwasher	per 100 .50	28-7250	Gear	.10
W-1506	Set Screw	per 100 1.60	28-7255	Tone and Local Distance Knob	.35
W-1781	Set Screw	per 100 2.00	28-7256	Control Shaft Cover	•
W-1839	Screw	per 100 1.25	28-7257	Back Housing	•
949-125	Wire	•	28-7260	Switch Gear	•
949-200	Wire	•	28-7261	Switch Gear	•
27-4609	Gasket	.10	28-7266	Idle Gear	•
27-4611	Pointer Knob	•	28-8009	Spring	per 100 .50
27-4687	Tuning and Volume Knob	•	28-8658	Spring	.03
27-5285	Retainer	.50	28-8762	Tuning Shaft	1.00
27-5286	Glass Retainer	•	28-8763	Volume Shaft	1.00
27-5351	Gasket	per 100 2.00	28-8764	Tone Control	1.00
27-5352	Dial Face Glass	.60	28-8765	Local — Distance Shaft	1.00
27-7132	Washer	per 100 .40	28-8774	Anti Back-lash Spring	•
27-7133	Ferrule	.01	28-8777	Spring	.15
27-8910	Glass	.25	38-5295	"A" Lead	.20
27-8981	Front Gasket	•	38-7993	"A" Lead	.35
28-1270	Housing	.01	42-1374	On-Off Switch	•
28-1272	Housing	per 100 .85	42-5754	Signal Panel Assembly	•
28-1456	Spring Washer	per 100 .75	42-5758	Signal Panel Shaft	•
28-2815	Clamp	•	42-5761	Pointer Assembly	•
28-3655	Drive Gear	.01	42-5763	Pointer Shaft Assembly	.25
28-4160	Friction Spring	•	42-5765	Gear and Sleeve Assembly	.20
28-5229	Dial Cover	.01	42-5798	Friction Gear Assembly	•
28-5238	Dial Gear (large)	•			

*Prices not available at this time.

PACKARD CONTROL---MODEL P-1535

